

COMPONENTES PARA TIMONERÍA HIDRÁULICA

HIDRAULIC STEERING GEAR / COMPONENTS



**LANTEK
HIDRAULICA S.L.**
Equipos y Sistemas Hidráulicos

LANTEK HIDRAULICA, S.L. Equipos y sistemas Hidráulicos
Landeta kalea, 2 Pab.8 Pol. Ind. Trobika - 48100 MUNGIA - Bizkaia
Tel: 94 674 21 62 Fax: 94 674 21 63 e-mail: lantekhidraulica@lantekhidraulica.com

ABATIMIENTO BOMBA CILINDRO NR. GIRO

Pump-Cylinder couplings rev.Nr.

ESLORA BARCO METROS	85 CV	150 CV	150 CV	300 CV	4<	6	6 ÷ 8	6 ÷ 8	8 ÷ 10	10 ÷ 12	12 ÷ 14	14 ÷ 16	16 ÷ 18	18 ÷ 20	20 ÷ 24	24 ÷ 26
CILINDRO BOMBA	FB 85 64 cm ³	FB 150L 100 cm ³	FB 150F 70 cm ³	FB 300N 116 cm ³	0/6N 57 cm ³	0/11N 105 cm ³	0/12N 120 cm ³	0/15N 150 cm ³	0/18N 175 cm ³	0/22N 219 cm ³	0/34N 339 cm ³	0/45N 442 cm ³	0/53 0/53N 530 cm ³ 0/52N 522 cm ³	0/78 0/78N 783 cm ³	0/103 1103 cm ³	0/158 1530 cm ³
C5/18 18 cm ³	3,5 N	5,5 N	3,9 N		3,2 N											
C5/25 C7/25 25 cm ³				4,6 N	2,3 M	4,2 N	4,8 N									
C7/37 37 cm ³							3,2 M	4 N	4,7 N	5,9 N	9,1 N	12 L				
C7/45 45 cm ³							2,7 P	3,3 M	3,9 M	4,9 M	7,5 M	9,8 N	11,8 L			
C7/56 56 cm ³												7,9 N	9,5 N	13,9 L	19,7 L	
C7/80 80 cm ³												5,5 P	6,6 M	9,8 N	13,8 N	19,1 L
C7/100 94 cm ³													5,6 P	8,3 M	11,7 N	16,3 N
C9/105 105 cm ³													5 P	7,4 M	10,5 N	14,6 N
C9/120 120 cm ³																12,8 M

GIRO DE BANDA A BANDA

ESFUERZO DE LA MANIOBRA

L = LIGERO

- light

N = NORMAL

- normal

M = MEDIANO

- medium

P = PESADO

- heavy

Turns from size to size

Stress of manoeuvre

FB 85

Bomba C5 / 18

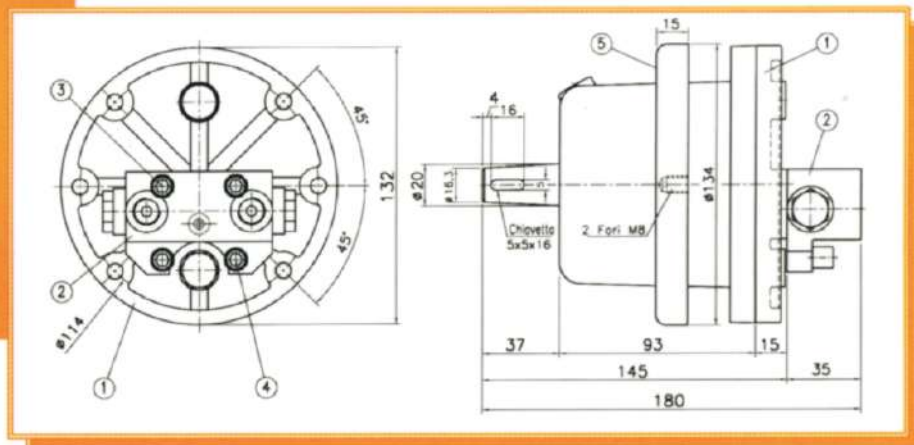

FB 85

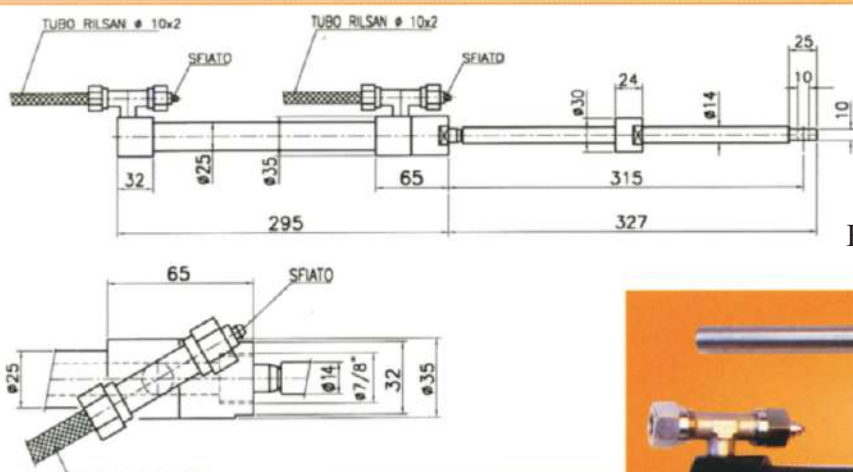

Características técnicas
Technical characteristics
 Volumen / Volume = 64 cm³
 Carrera / Stroke = 208 mm
 Fueraborda / Outboard = 85 CV



FB 150 L

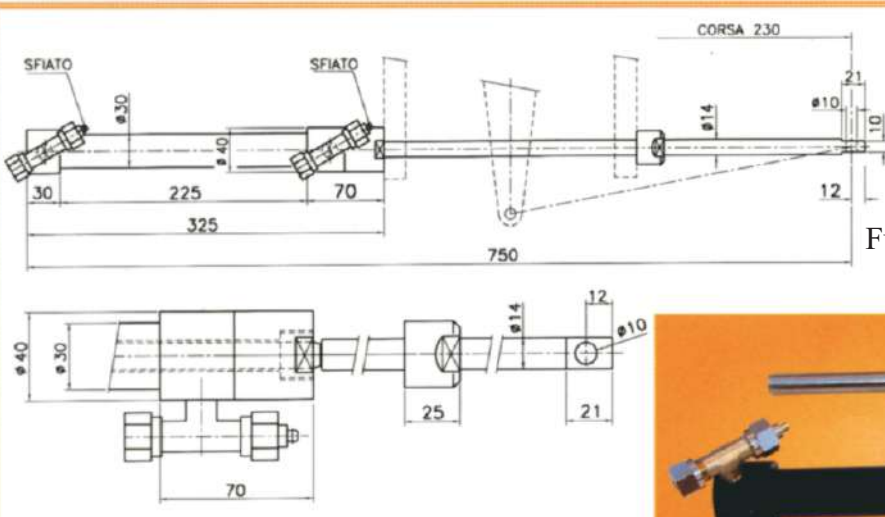

Características técnicas
Technical characteristics
 Volumen / Volume = 100 cm³
 Carrera / Stroke = 230 mm
 Fueraborda / Outboard = 150 CV





Bomba C5/18

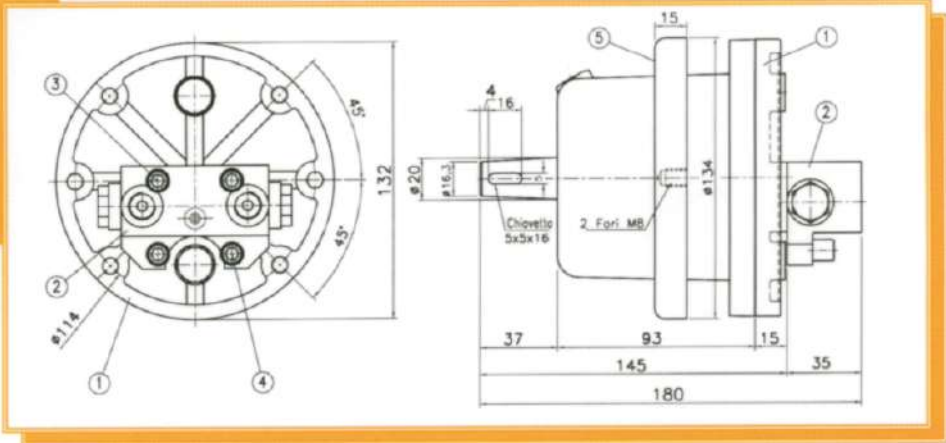

CL. 0/6 N

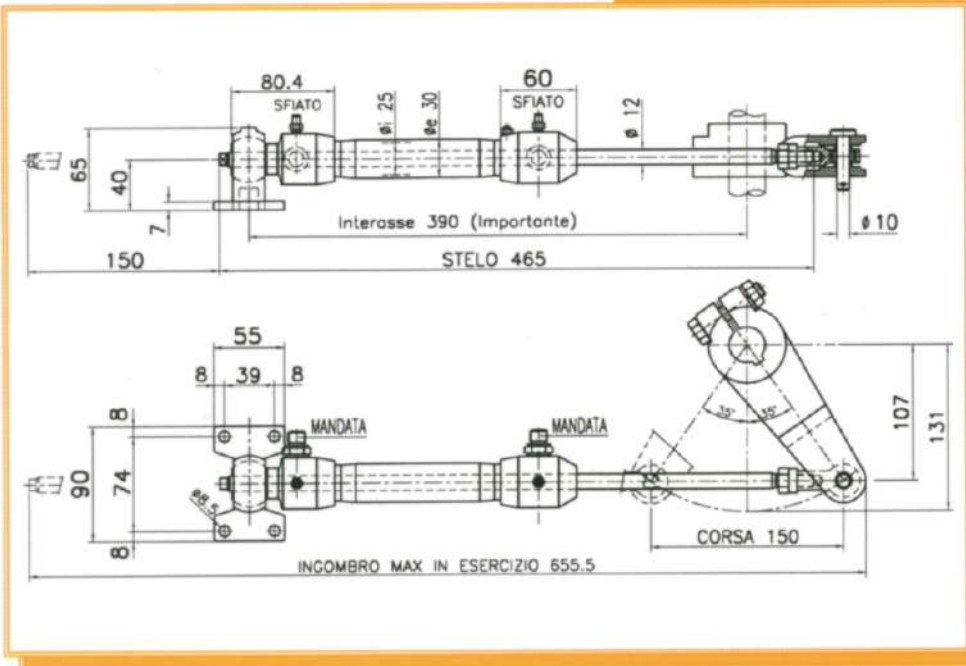

**Caratteristiche tecniche
Technical characteristics**

- Volumen / Volume = 57 cm³
- Carrera / Stroke = 150 mm
- Momento
Max torque = 27 Kgm
- Presión / Pressure = 75 Bar
- Fuerza / Force = 283.5 Kg

C5/25

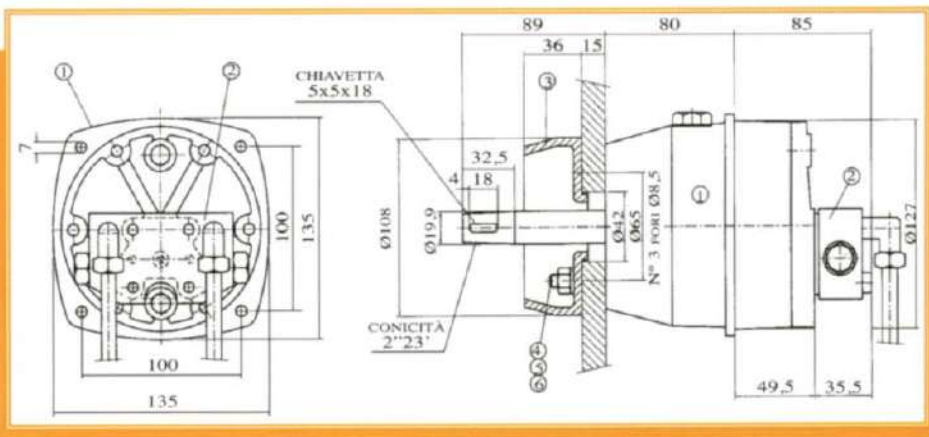

C7/25

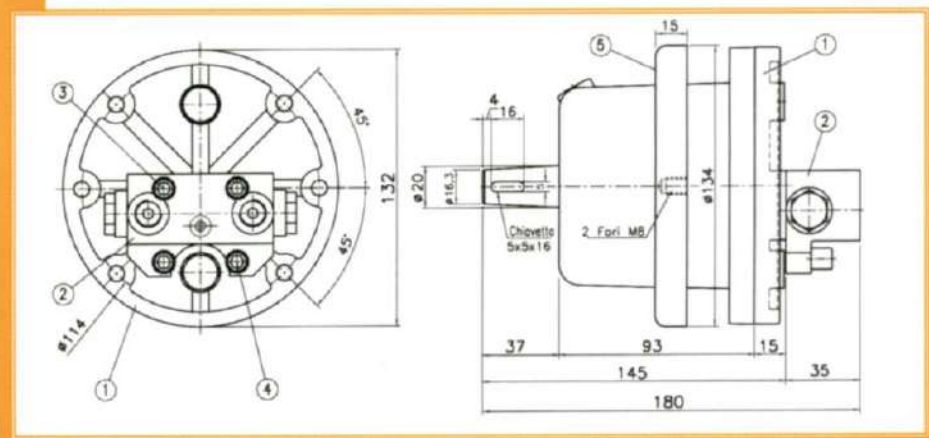

Características técnicas Technical characteristics

- Volumen / Volume = 105 cm³
- Carrera / Stroke = 175 mm
- Momento / Max torque = 51 Kgm
- Presión / Pressure = 75 bar
- Fuerza / Force = 452 Kg

CL. 0/11 N

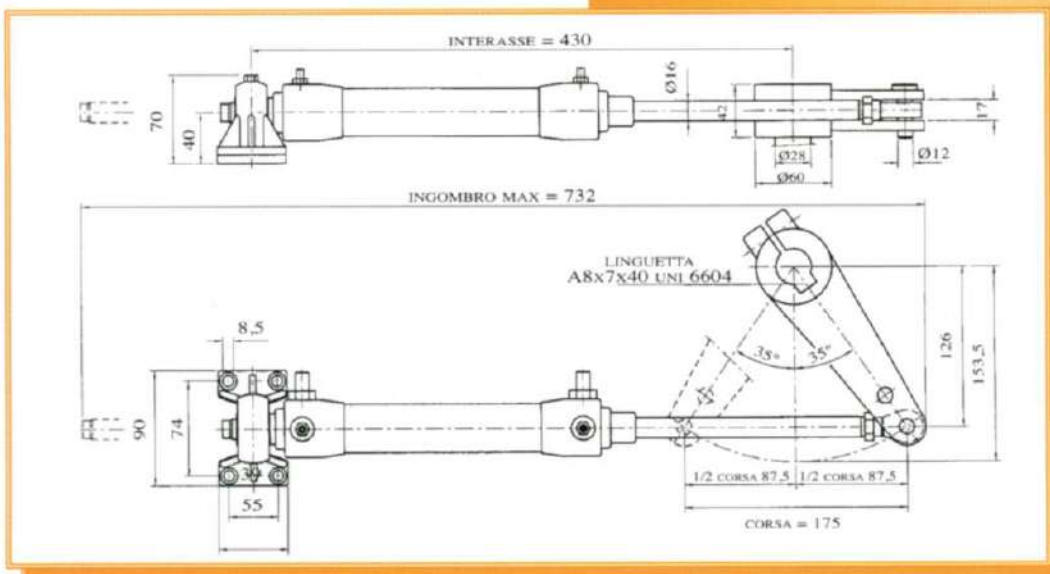

C5/25

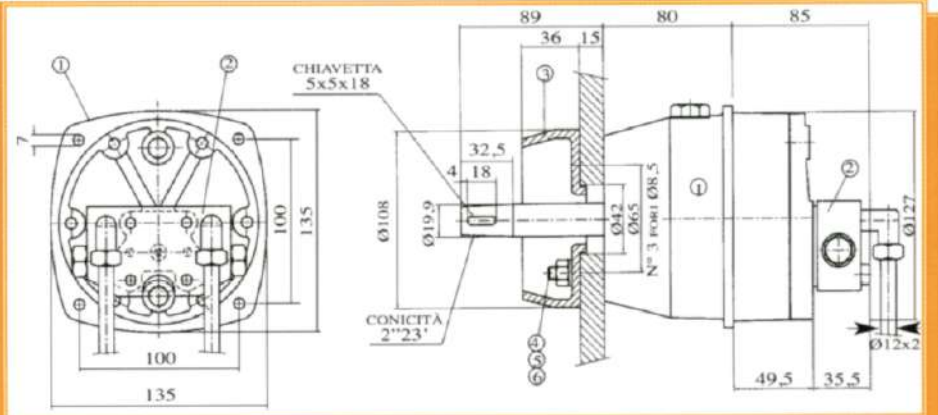

C7/25

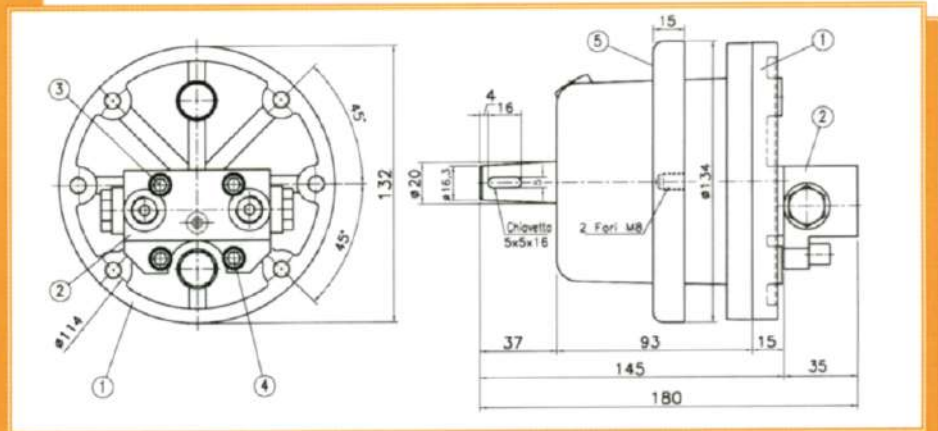

Características técnicas Technical characteristics

- Volumen / Volume = 120 cm³
- Carrera / Stroke = 200 mm
- Momento /
Max torque = 58 Kgm
- Presión / Pressure = 75 bar
- Fuerza / Force = 452 Kg

CL. 0/12 N

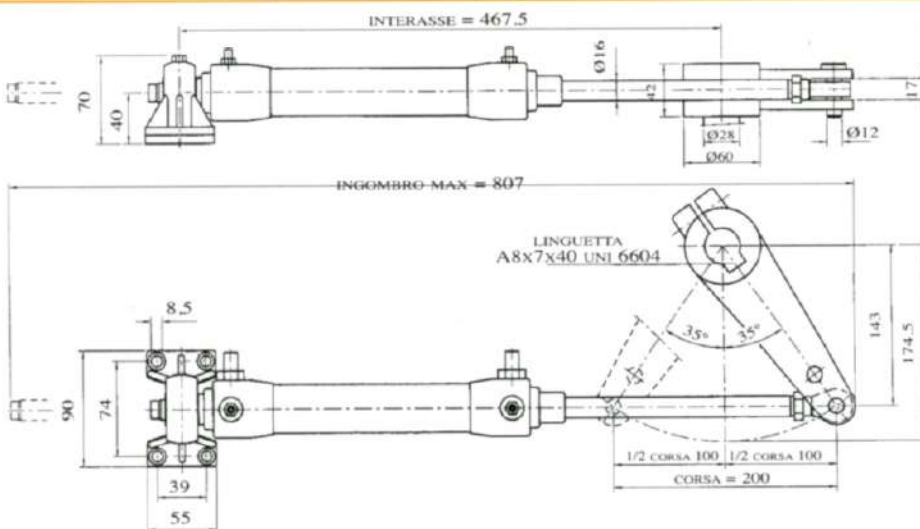

C7/37

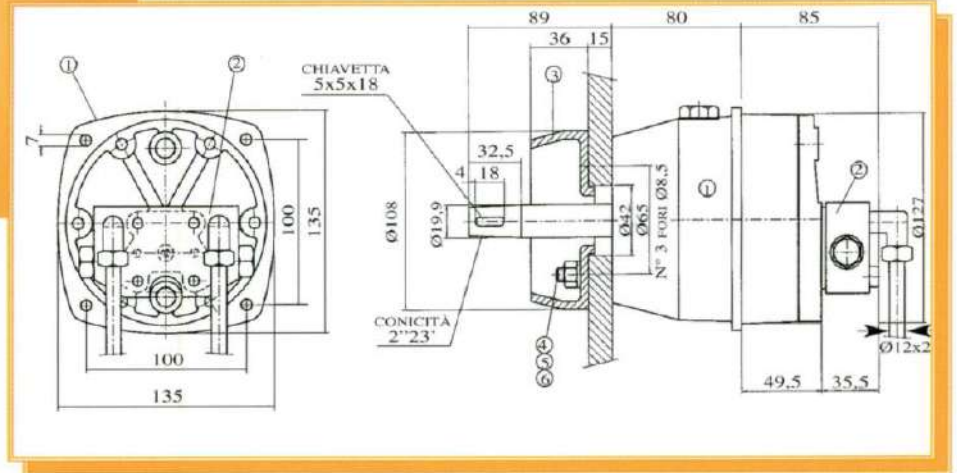

CL. 0/15 N



Características técnicas Technical characteristics

Volumen / Volume	= 150 cm ³
Carrera / Stroke	= 250 mm
Momento / Max torque	= 67 Kg _m
Presión / Pressure	= 75 bar
Fuerza / Force	= 452 Kg

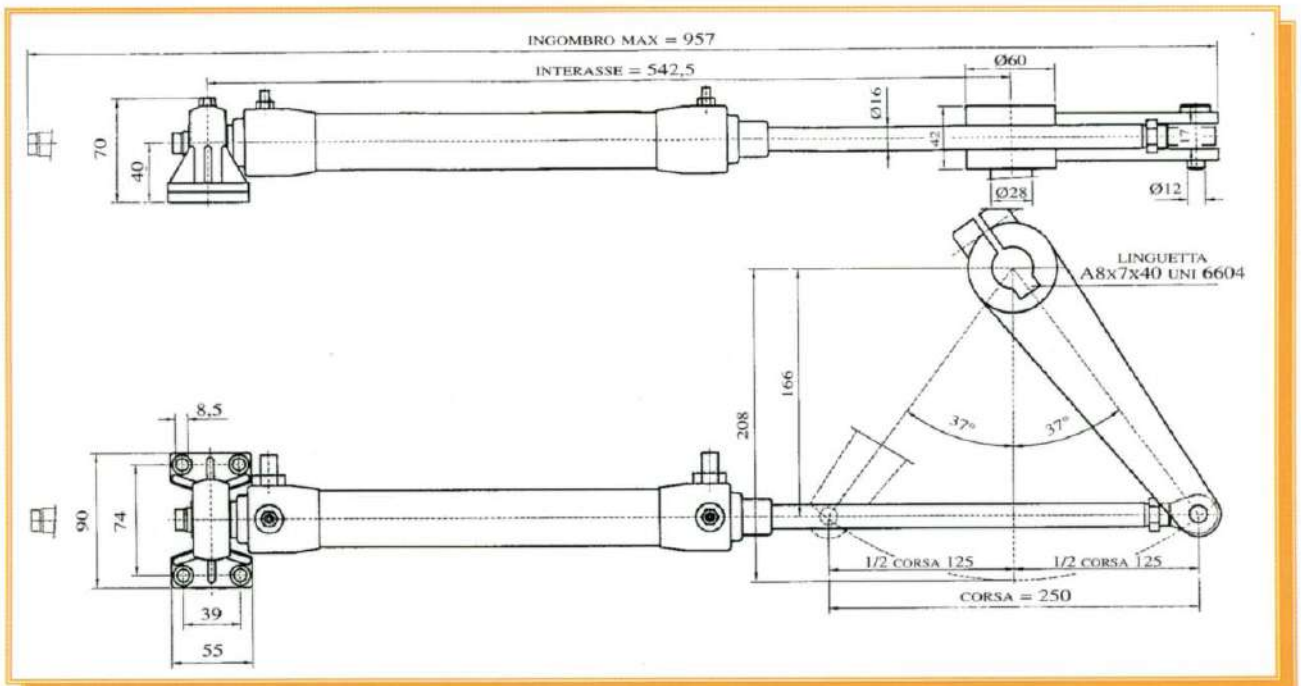

C7/37

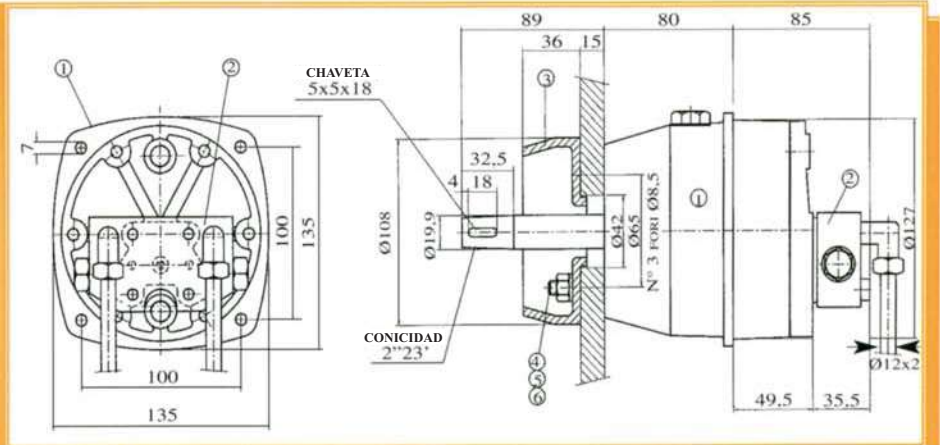

**CL. 0/18 N - CL. 0/22 N
CL. 0/34 N**

CL. 0/18 N

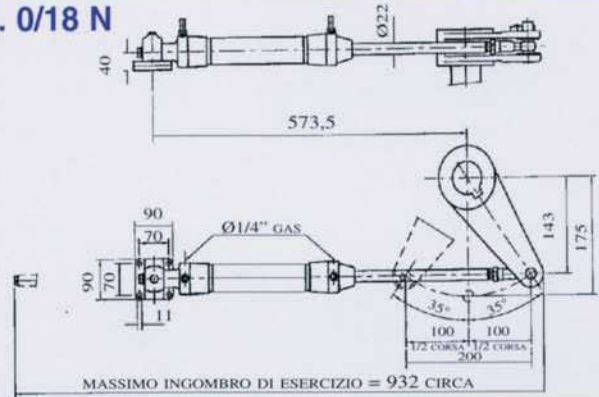

CL. 0/22 N

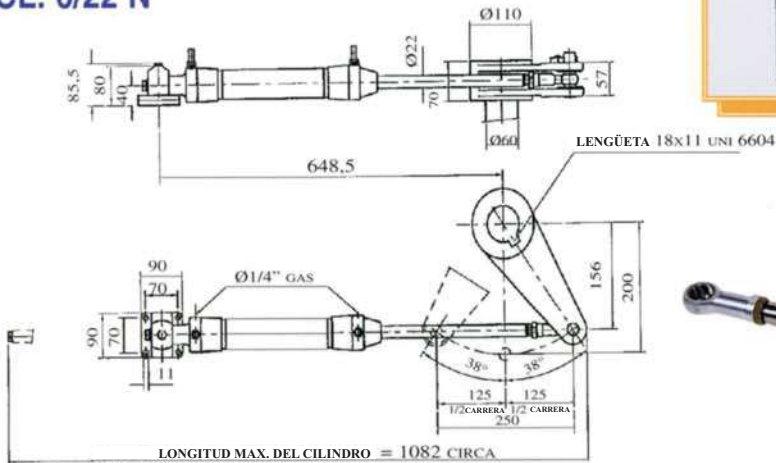

Características técnicas Technical characteristics

	CL.0/18 N	CL.0/22N	CL.0/34 N
Volumen / Volume	175	219	339
cm ³	cm ³	cm ³	cm ³
Carrera / Stroke	200	250	230
mm	mm	mm	mm
Momento / Max torque	112	123	217
Kgm	Kgm	Kgm	Kgm
Presión / Pressure	100	100	100
bar	bar	bar	bar
Fuerza / Force	876	876	1473
Kg	Kg	Kg	Kg

CL. 0/34 N

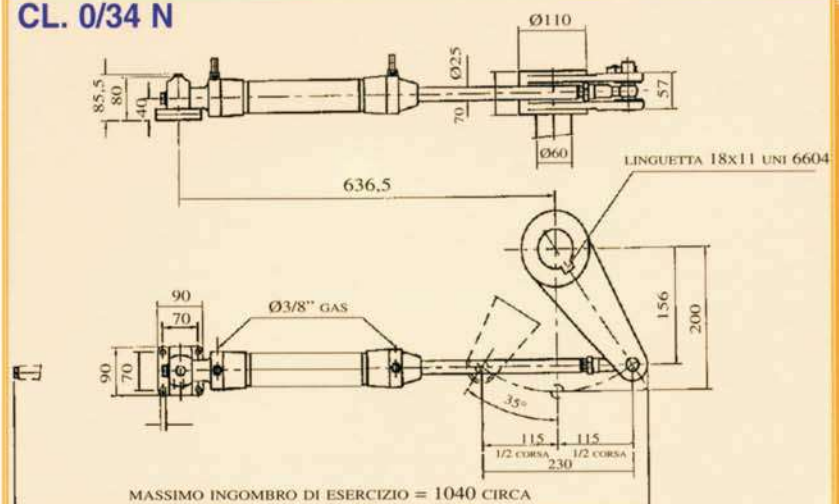

C7/45

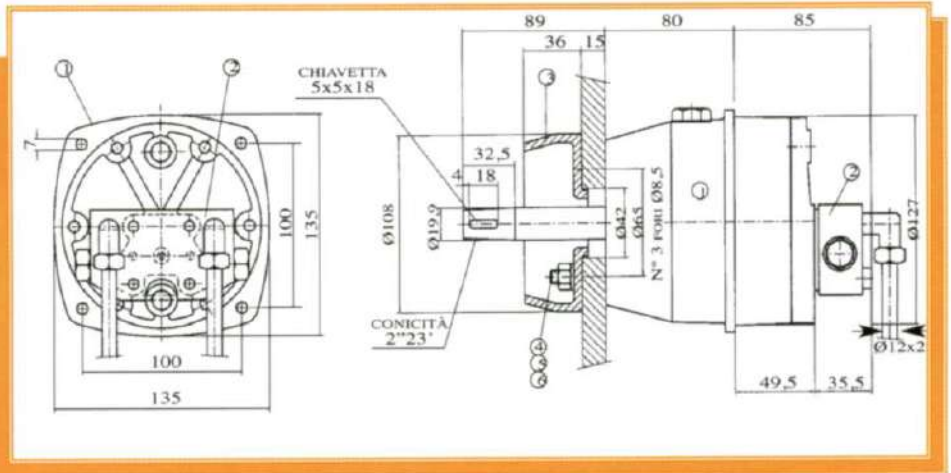

CL. 0/45 N



CL. 0/45 N

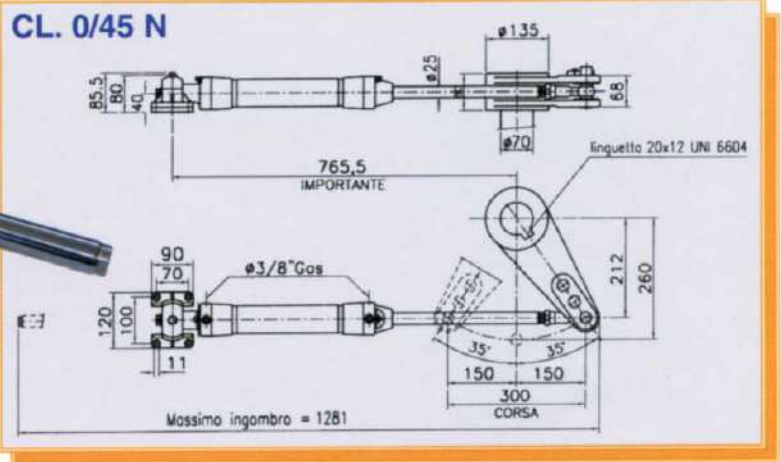

CL. 0/34 N FC

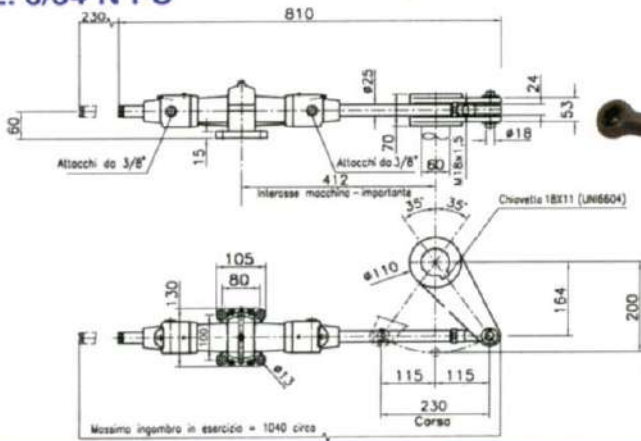

**CL. 0/34 N FC
CL. 0/45 N FC**

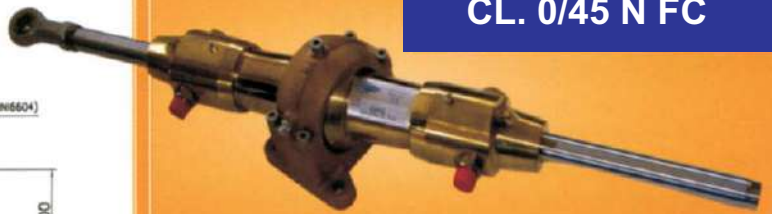

**Características técnicas
Technical characteristics**

CL. 0/45 N FC

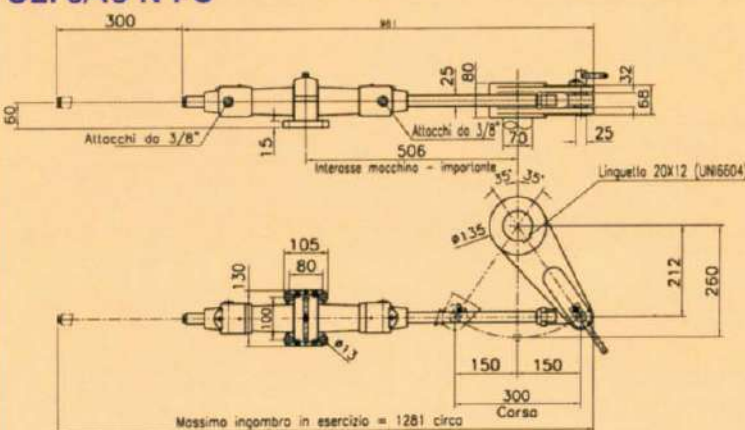

	CL.0/45 N	CL.0/34N FC	CL.0/45N FC
Volumen / Volume	442	339	442
cm ³		cm ³	cm ³
Carrera / Stroke	300	230	300
mm		mm	mm
Momento / Max torque	281	217	281
Kgm		Kgm	Kgm
Presión / Pressure	100	100	100
bar		bar	bar
Fuerza / Force	1473	1473	1473
Kg		Kg	Kg

C7/55

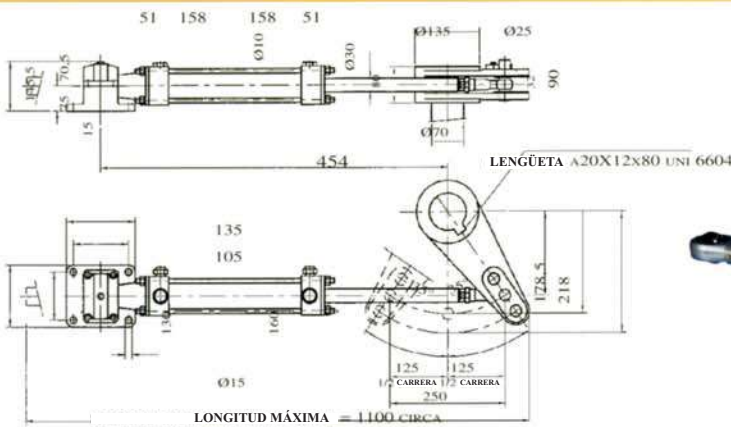
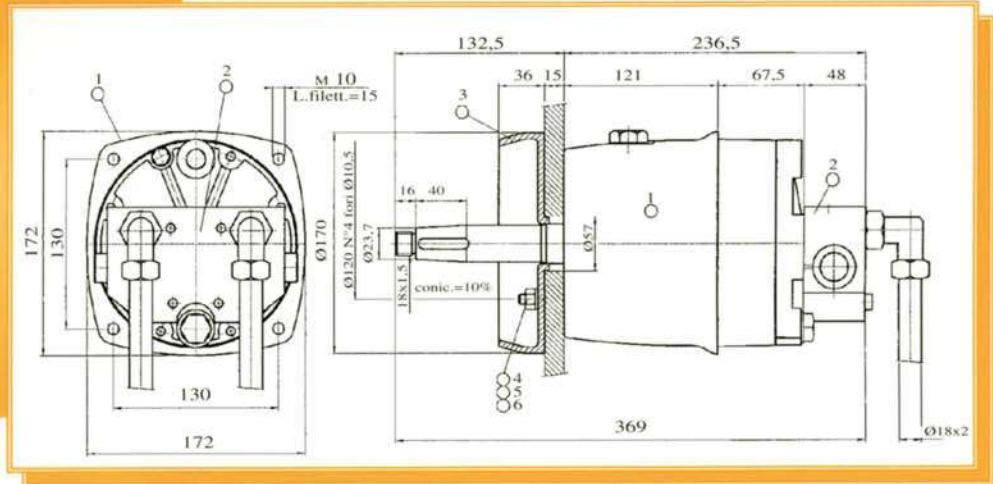

CL. 0/53 FC



CL. 0/53

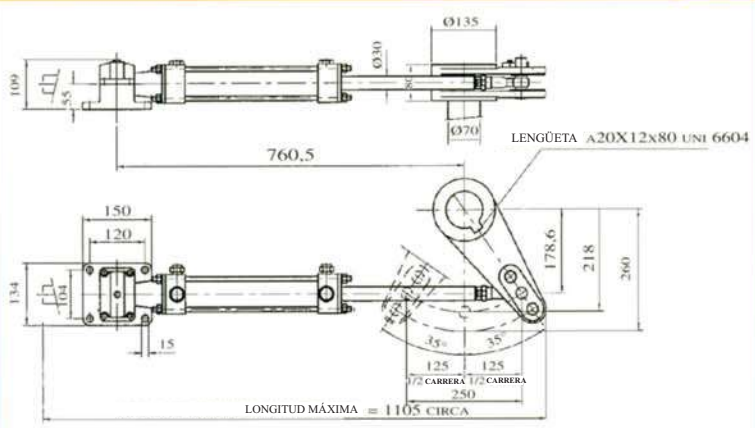

**Características técnicas
Technical characteristics**

- Volumen / Volume = 530 cm³
- Carrera / Stroke = 250 mm
- Momento / Max torque = 340 Kgm
- Presión / Pressure = 100 bar
- Fuerza / Force = 2119 Kg

C7/56

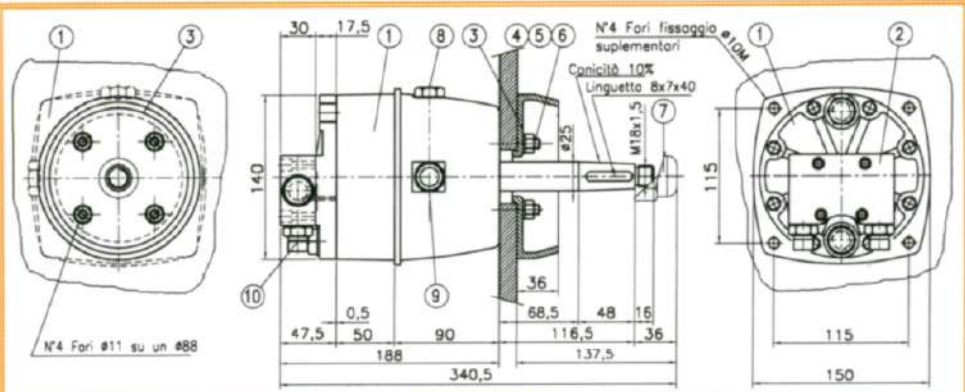

CL. 0/52 N

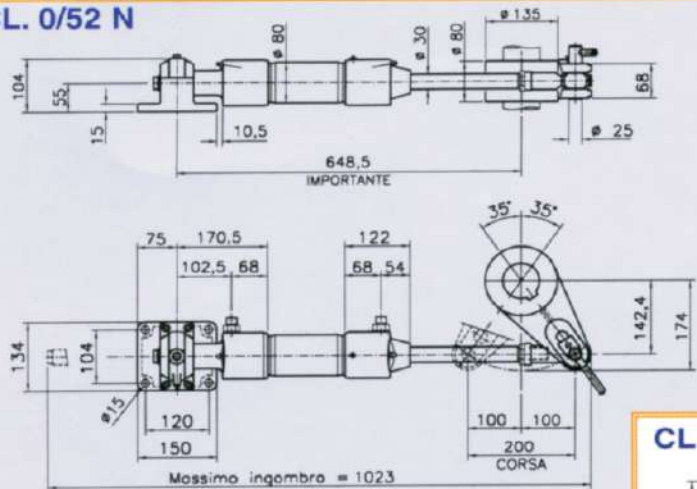

CL. 0/53 N

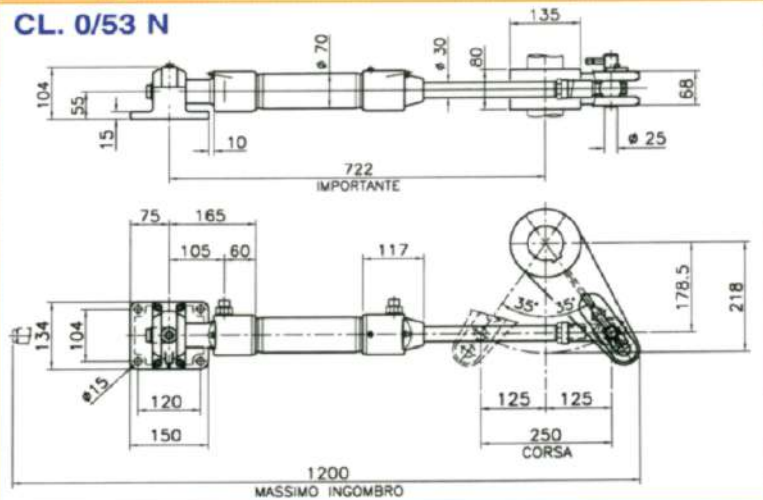

- CL 0/ 52 N
- CL 0/ 53 N
- CL 0/ 78 N



CL. 0/78 N

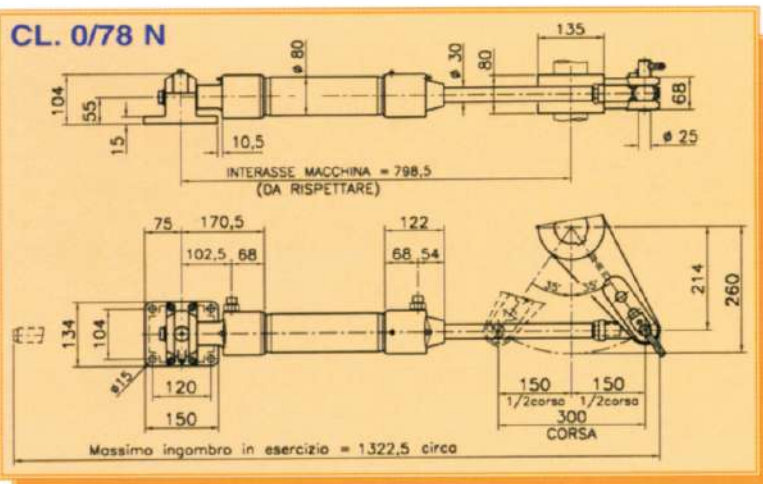

Características técnicas Technical characteristics

- Volumen / Volume
- Carrera / Stroke
- Momento / Max torque
- Presión / Pressure
- Fuerza / Force

	CL.0/52 N	CL.0/53N	CL.0/78 N
Volumen / Volume	522	530	783
cm ³	cm ³	cm ³	cm ³
Carrera / Stroke	200	250	300
mm	mm	mm	mm
Momento / Max torque	334	340	502
Kgm	Kgm	Kgm	Kgm
Presión / Pressure	100	100	100
bar	bar	bar	bar
Fuerza / Force	2610	2195	2611
Kg	Kg	Kg	Kg

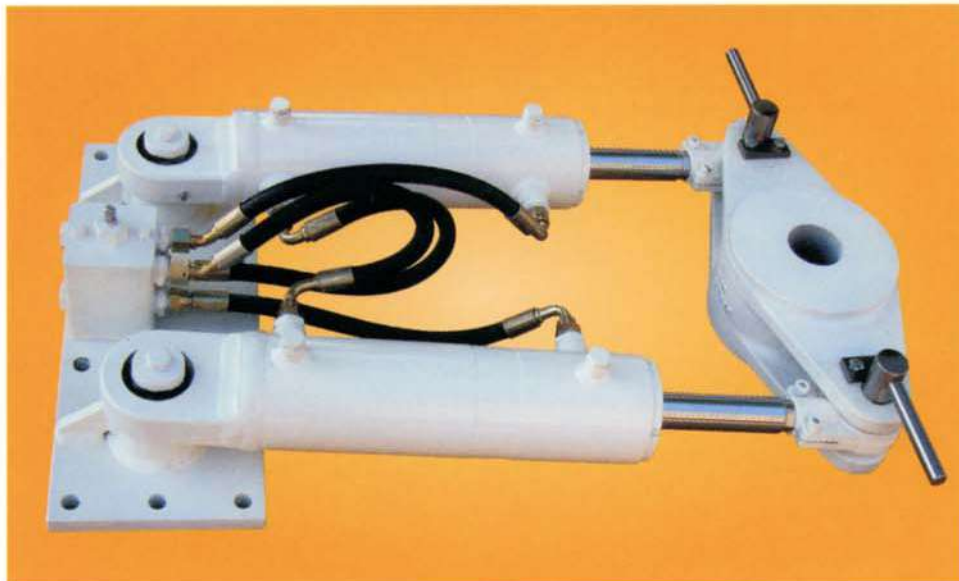

**C9/105 - C9/120 - C9/150
C11/150 - C11/200**



C7/80

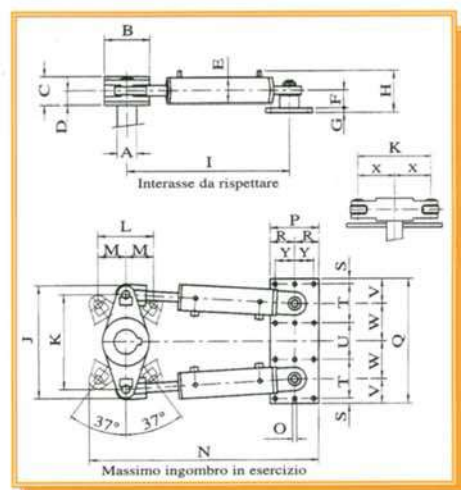
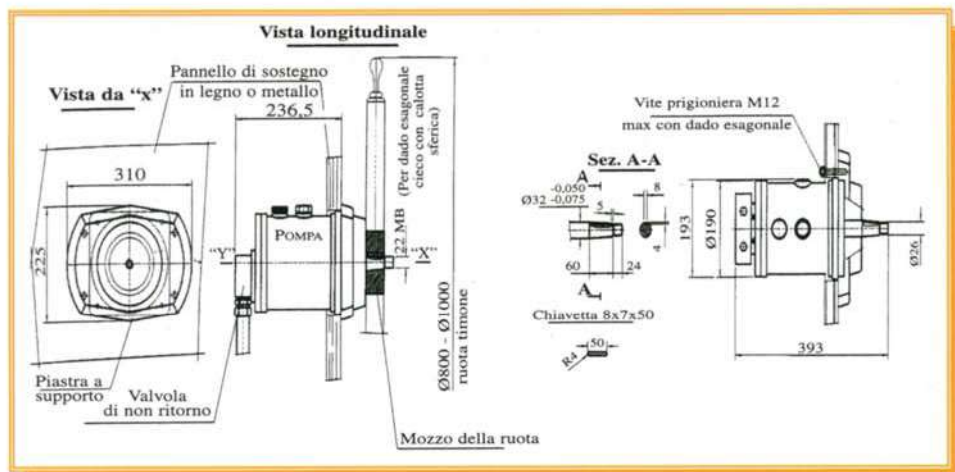

Características - Characteristics

TIPO TYPE	TRASMET. TRANS.	M	pe	V	F	C	n	DN	G	G1
CL. 2B101*	C7/80 C9/105	630	100	1067	5930	180	13,3 10,2	22x2	15	44
CL. 2B151*	C9/105	890	100	1481	6734	220	14,1	22x2	48	76
CL. 2B201*	C9/120	1186	100	1999	9091	220	16,6	22x2	48	100
CL. 2B301	C9/120 C9/150 C11/150	1992	110	3038	12614	265	25,3 20,3	22x2	48	120
CL. 2B401	C11/200	2622	100	4123	13744	300	21,6	22x2	51	140
CL. 2B632	C11/200	4026	105	6322	13744	460	31,6	22x2	51	155

M: Kpm - Momento max - Max torque
 pe: Kp/cm2 - Presión de trabajo - Rated pressure
 V: cm3 - Volumen - Piston thrust
 F: Kp - Fuerza - Piston thrust
 C: mm - Carrera - Piston stroke
 n: Giro de rueda de banda a banda - Steering wheel turns from side to side
 DN: Diámetro de tubo - Pipes diameter (Mannesmann)
 G: Kp - Peso; transmisor - Transmitter weight
 G1: Kg - Peso; actuador - Actuator weight

Otras dimensiones - Overall dimensions

TIPO TYPE	A	B	C	D	E	F	G	H	I	J	K	L	M	N	O	P	Q	R	S	T	U	V	W	X	Y	Z
CL. 2B101*	82	145	80	40	80	65	15	140	570	356	296	180	90	754	14,5	130	376	65	17,5	105	131	70	118	148	47,5	-
CL. 2B151*	92	185	110	55	85	62	18	142,5	653	434	364	220	110	896	16,5	190	480	95	20	150	140	95	145	182	75	-
CL. 2B201*	103	185	110	55	100	67	18	161	654	434	364	220	110	897	16,5	190	480	95	20	150	140	95	145	182	75	-
CL. 2B301	120	220	130	65	110	65	20	160	743,5	530	440	265	132,5	1016	16,5	190	541	95	20	150	201	95	175,5	220	75	-
CL. 2B401	130	235	140	70	120	85	20	185	876	610	520	300	150	1181	20,5	220	644	110	20	180	244	110	212	260	90	-
CL. 2B632	170	310	170	85	120	85	20	185	1116	862	772	460	230	1505	20,5	220	840	110	20	180	440	110	310	386	90	-

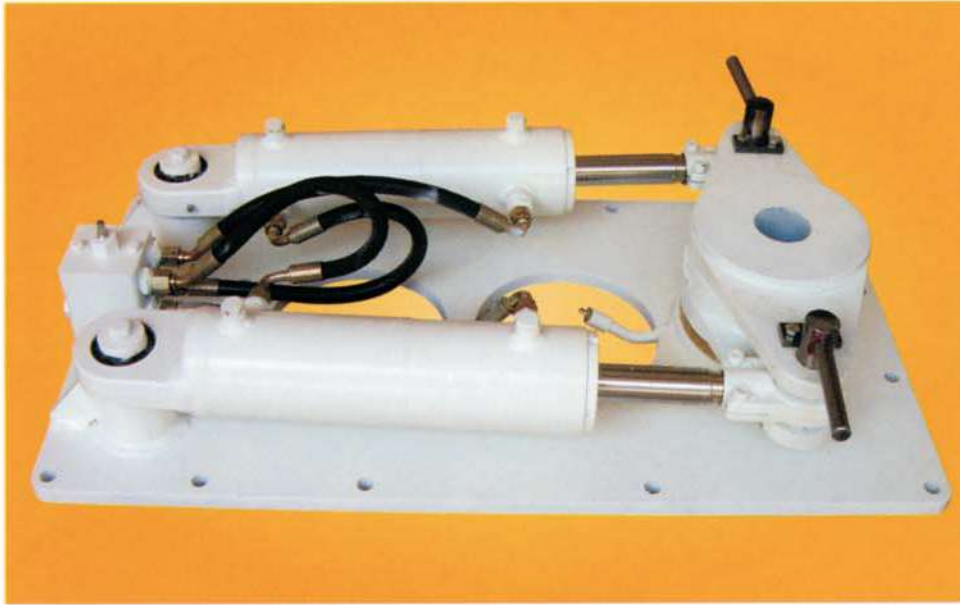

**C9/105 - C9/120 - C9/150
C11/150 - C11/200**



C7/80

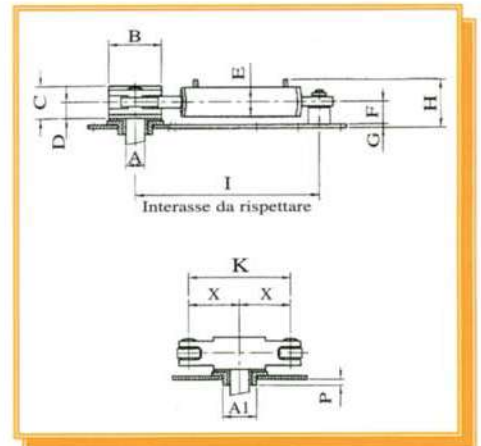
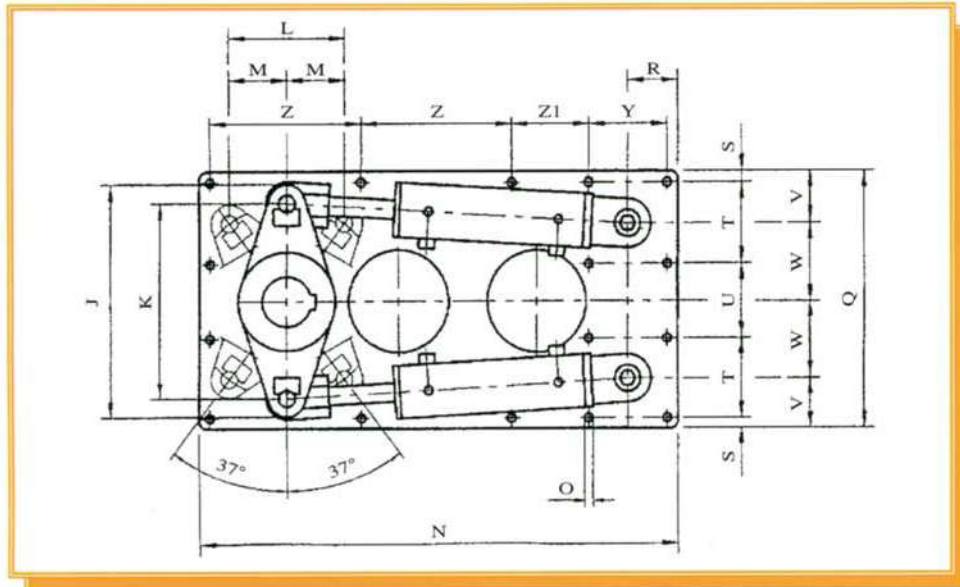

Características - Characteristics

TIPO TYPE	TRASMET. TRANS.	M	pe	V	F	C	n	DN	G	G1
CL. 2B101/SB	C7/80 C9/105	630	100	1067	5930	180	13,3 10,2	22x2	15	94
CL. 2B151/SB	C9/105	890	100	1481	6734	220	14,1	22x2	48	131
CL. 2B201/SB	C9/120	1186	100	1999	9091	220	16,6	22x2	48	165
CL. 2B301/SB	C7/80 C9/105 C11/150	1992	110	3038	12614	265	25,3 20,3	22x2	48	200
CL. 2B401/SB	C11/200	2622	100	4123	13744	300	21,6	22x2	51	240

M: Kpm - Momento max. - Max. Torque
 pe: Kp/cm2 - Presión de trabajo - Rated pressure
 V: cm3 - Volumen - Piston thrust
 F: Kp - Fuerza - Piston thrust
 C: mm - Carrera - Piston stroke
 n: Giro de rueda de banda a banda - Steering wheel turns from side to side
 DN: Diámetro de tubo - Pipes diameter (Mannesmann)
 G: Kp - Peso; transmisor - Transmitter weight
 G1: Kg - Peso; actuador - Actuator weight

Otras Dimensiones - Overall dimensions

TIPO TYPE	A	A1	B	C	D	E	F	G	H	I	J	K	L	M	N	O	P	Q	R	S	T	U	V	W	X	Y	Z	Z1
CL. 2B101/SB	82	130	145	80	40	80	65	15	140	570	356	296	180	90	725	14,5	30	376	65	17,5	105	131	70	118	148	95	230	135
CL. 2B151/SB	92	155	185	110	55	85	87	18	175	653	434	364	220	110	900	16,5	30	480	95	20	150	140	95	145	182	150	275	160
CL. 2B201/SB	103	180	185	110	55	100	87	18	175	654	434	364	220	110	900	16,5	30	480	95	20	150	140	95	145	182	150	275	160
CL. 2B301/SB	120	190	220	130	65	110	100	20	195	743,5	530	440	265	132,5	990	16,5	45	541	95	20	150	201	95	175,5	220	150	300	200
CL. 2B401/SB	130	200	235	140	70	120	105	20	212	876	610	520	300	150	1146	16,5	55	644	110	20	180	244	110	212	260	180	330	230

Tabla de combinación central hidra./actuadores
Table combinations power packs / actuators

Central hidr. / Actuador	CC-02	CC-03	AC-02R	AC-03R	AC-05R	CC-05	CC-075	CC-1	CC-1A	CC-4A	CC-4	CC-7A	CC-10
FB-85 / 64 cm ³													
FB-300N / 115 cm ³			13 SEC.	6 SEC.									
CL.0-6N / 57 cm ³	6 SEC.		7 SEC.										
CL.0-11N / 105 cm ³	12 SEC.	6 SEC.	12 SEC.	6 SEC.									
CL.0-12N / 120 cm ³			14 SEC.	7 SEC.	5 SEC.	5 SEC.							
CL.0-15N / 150 cm ³					6 SEC.	6 SEC.							
CL.0-18N / 175 cm ³					7 SEC.	7 SEC.							
CL.0-22N / 219 cm ³					8 SEC.	9 SEC.							
CL.0-34N / 339 cm ³							8 SEC.						
CL.0-45N / 442 cm ³							11 SEC.	6 SEC.	6 SEC.	8 SEC.			
CL.0-52N / 522 cm ³								7 SEC.	7 SEC.	9 SEC.	7 SEC.		
CL.0-53N / 530 cm ³								7 SEC.	7 SEC.	9 SEC.	7 SEC.		
CL.0-78N / 788 cm ³											10 SEC.		
CL.0-103 / 1103 cm ³												14 SEC.	
CL.0-158 / 1530 cm ³													14 SEC.

Esquema
Scheme

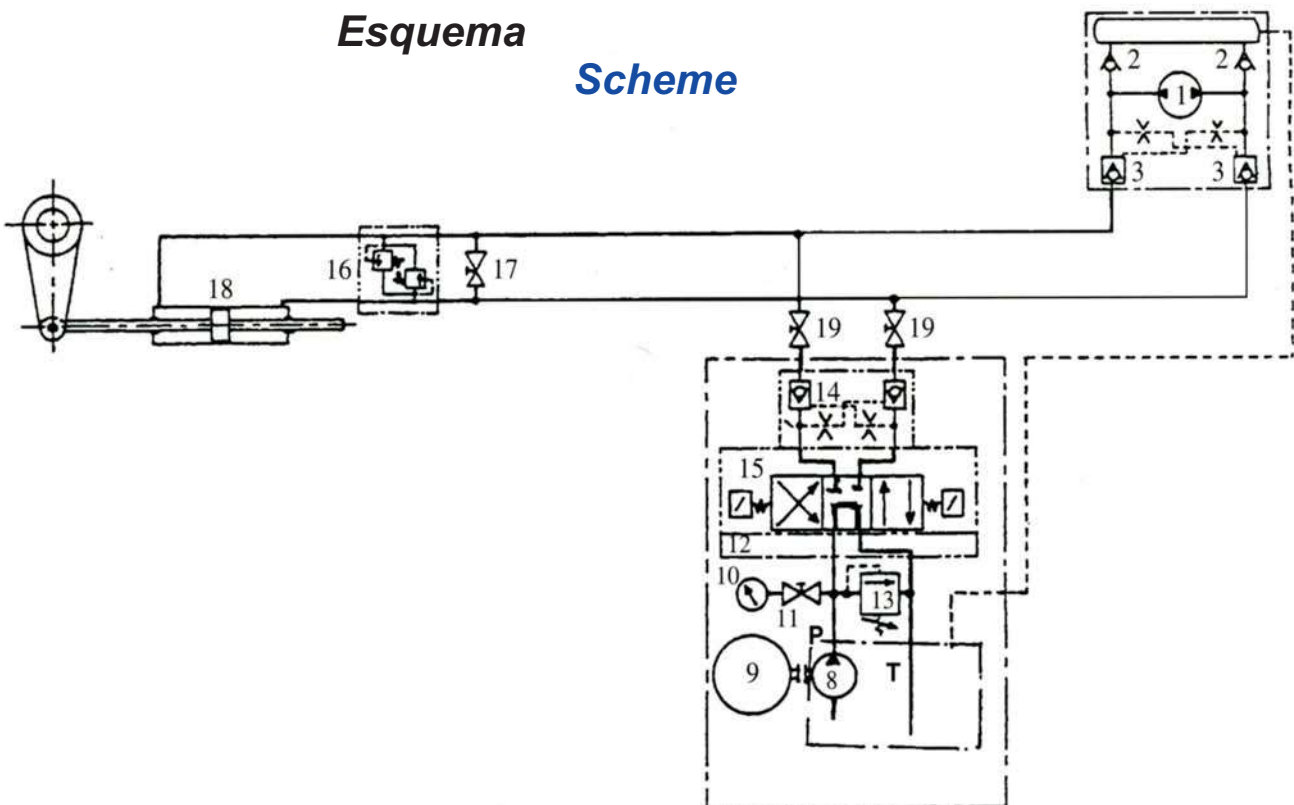

CENTRALITAS / Power Packs

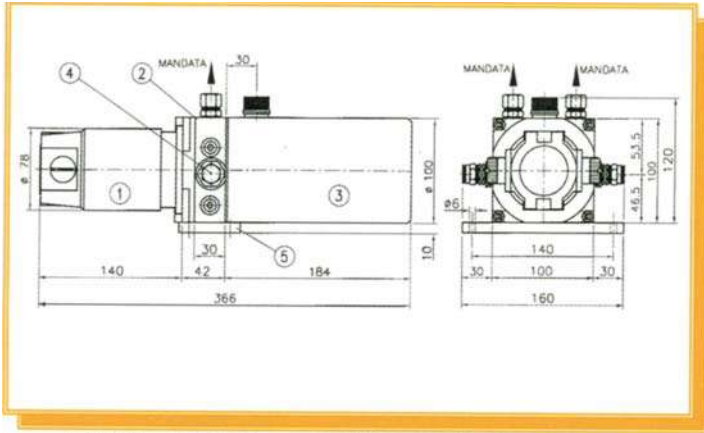

AC 02R - Q: 0,5 l/mn - P: 40W - U: 12-24 V-CC - 4 Kg

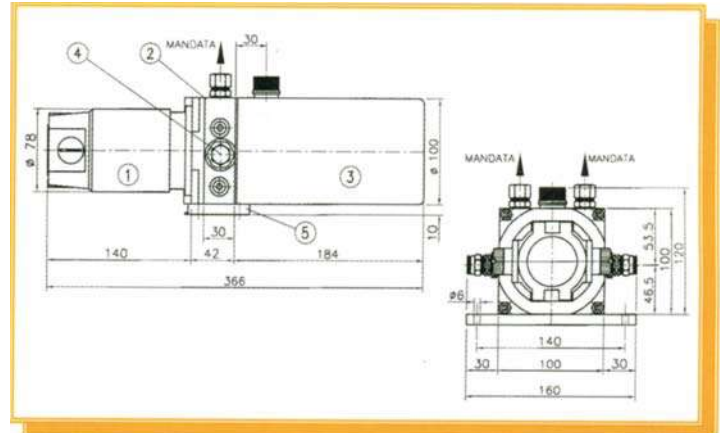

AC 03R - Q: 1,1 l/mn - P: 80W - U: 12-24 V-CC - 4 Kg

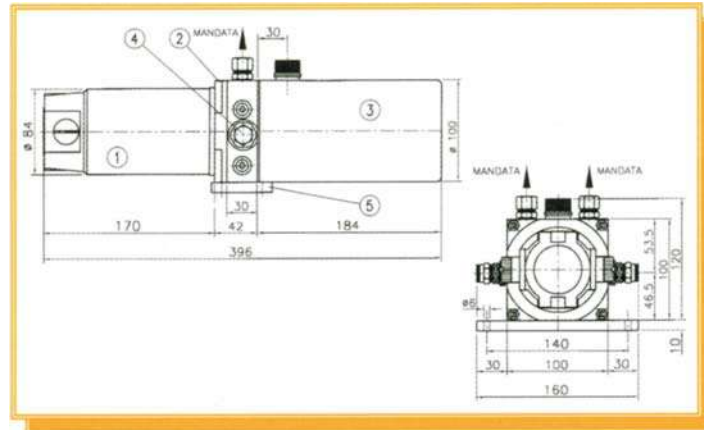

AC 05R - Q: 1,6 l/mn - P: 125W - U: 12-24 V-CC - 6 Kg

AC 02R AC 03R AC 05R

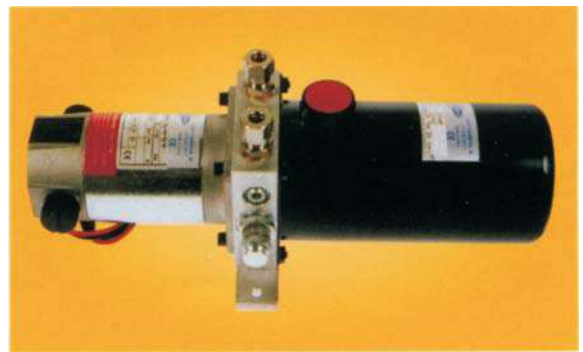

CC 02 CC 03 CC 05

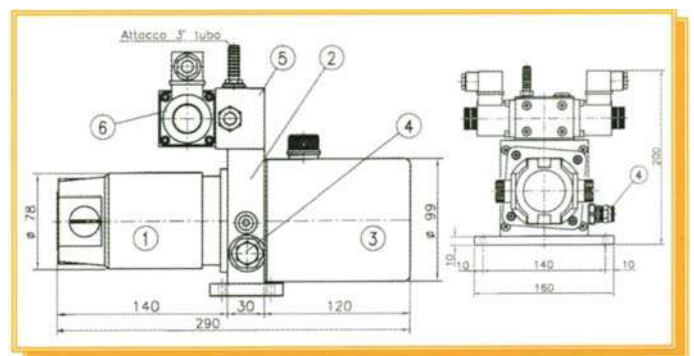
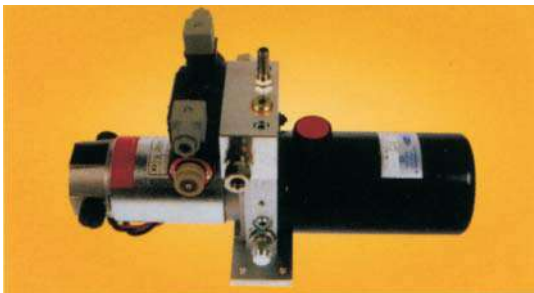

CC 02 - Q: 0.5 l/mn - P: 40W - U: 12-24 V-CC - 7,5 Kg

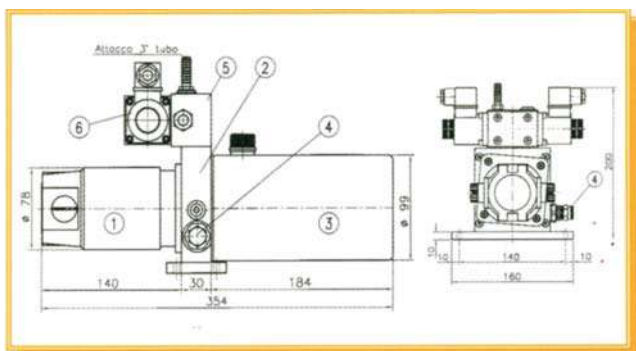

CC 03 - Q: 0.8 l/mn - P: 80W - U: 12-24 V-CC - 8 Kg

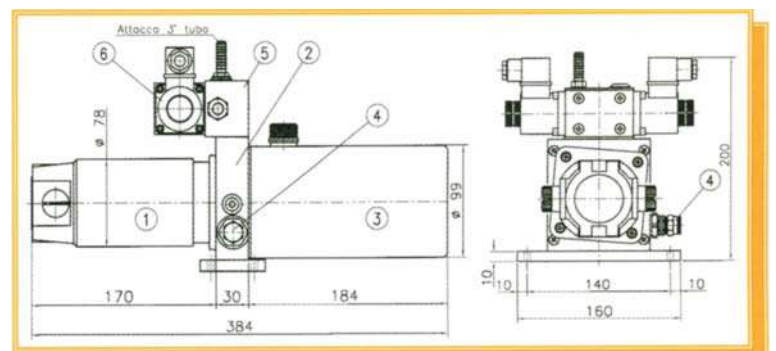

CC 05 - Q: 1.4 l/mn - P: 125W - U: 12-24 V-CC - 10 Kg

CENTRALITAS / POWER PACKS

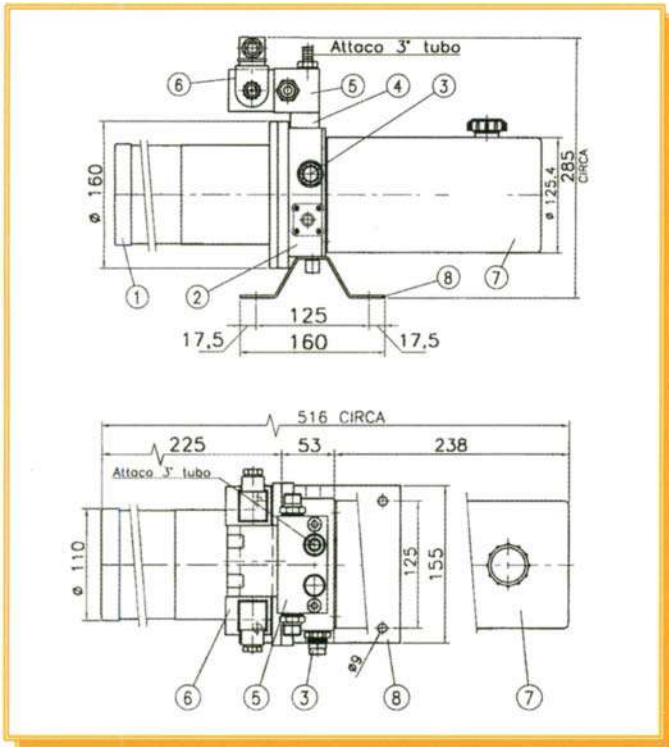

CC 075 - Q: 2.4 l/mn - P: 300W - U: 12-24 V-CC - 10 Kg

AC 02R - AC 03R - AC 05R

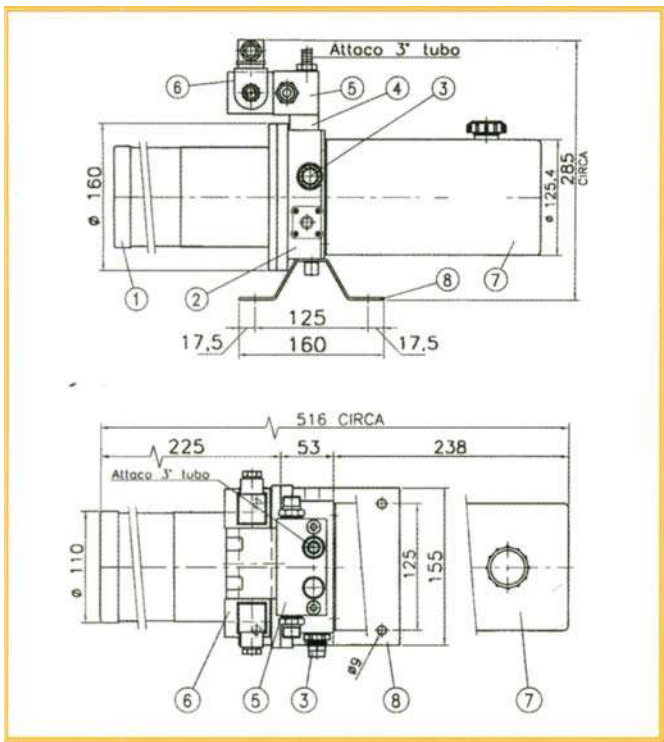
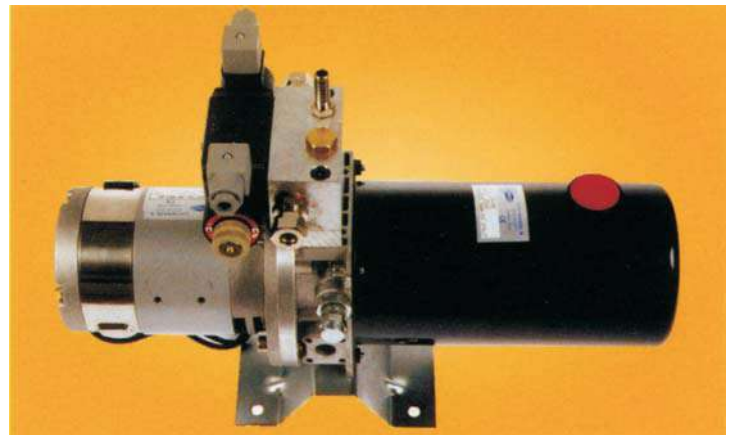

CC 1 - Q: 4.6 l/mn - P: 600W - U: 12 V-CC - 24 Kg

CC 1A - Q: 4.8 l/mn - P: 500W - U: 24 V-CC - 24 Kg

CENTRALITAS / POWER PACKS

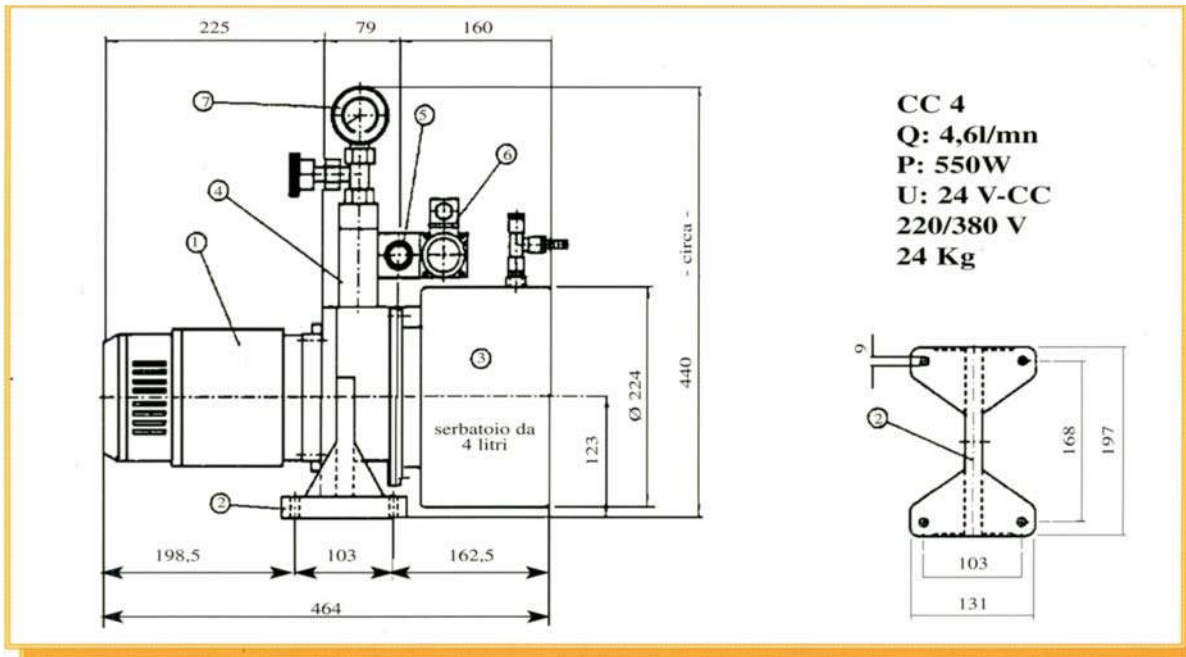

TIPO - TYPE: Y

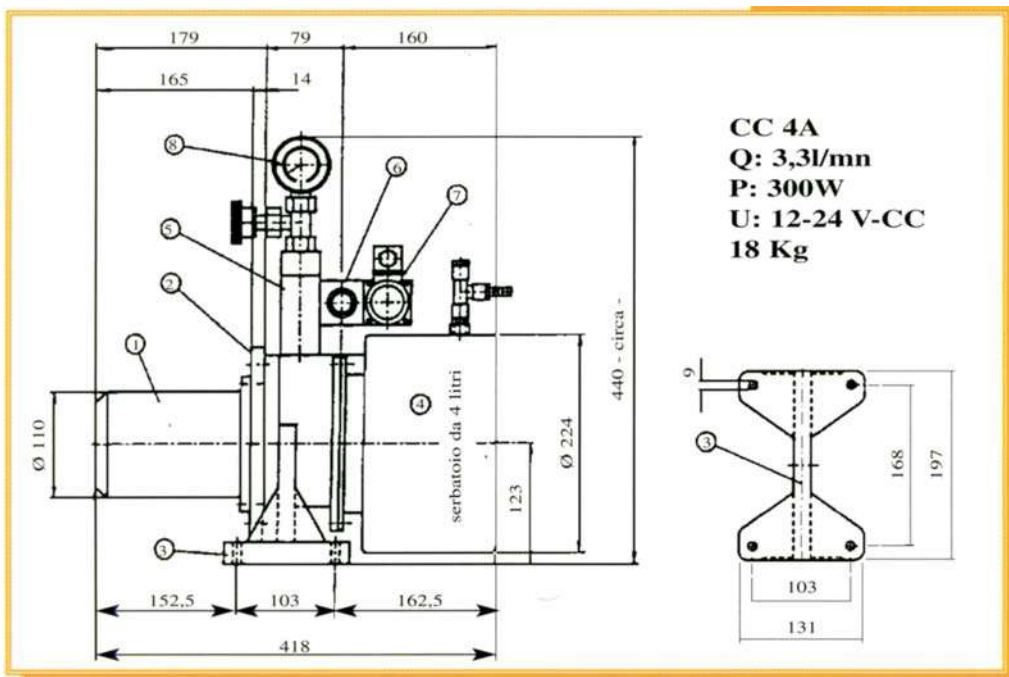

CENTRALITAS / POWER PACKS

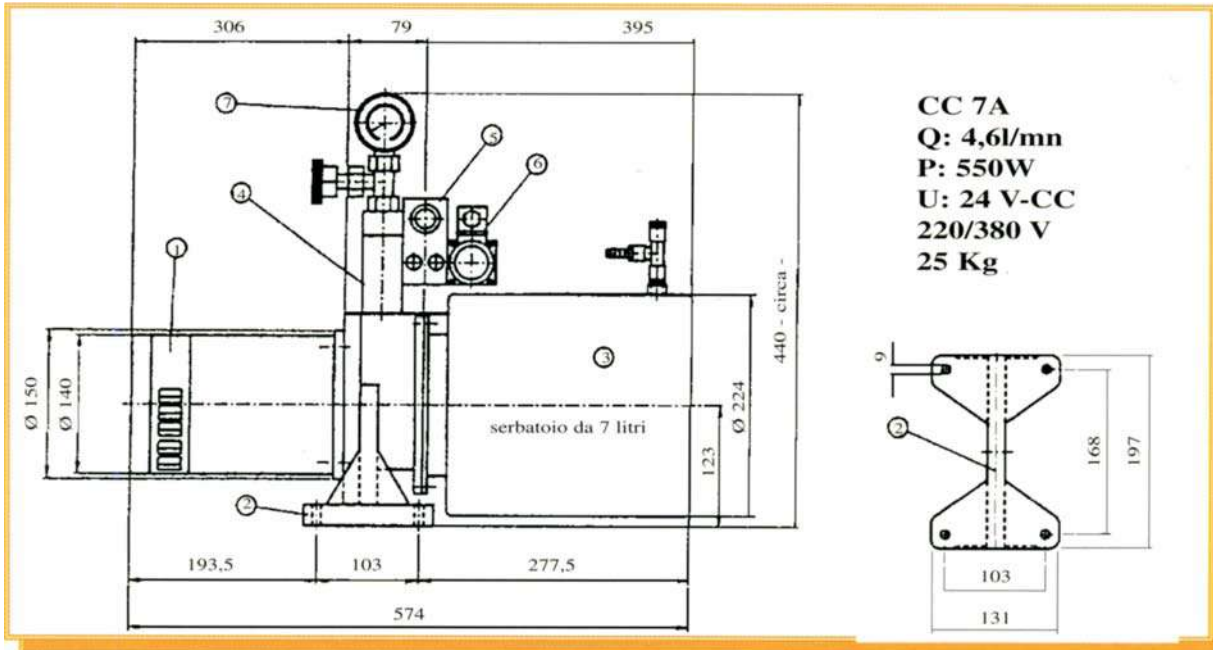

TIPO TYPE: Y

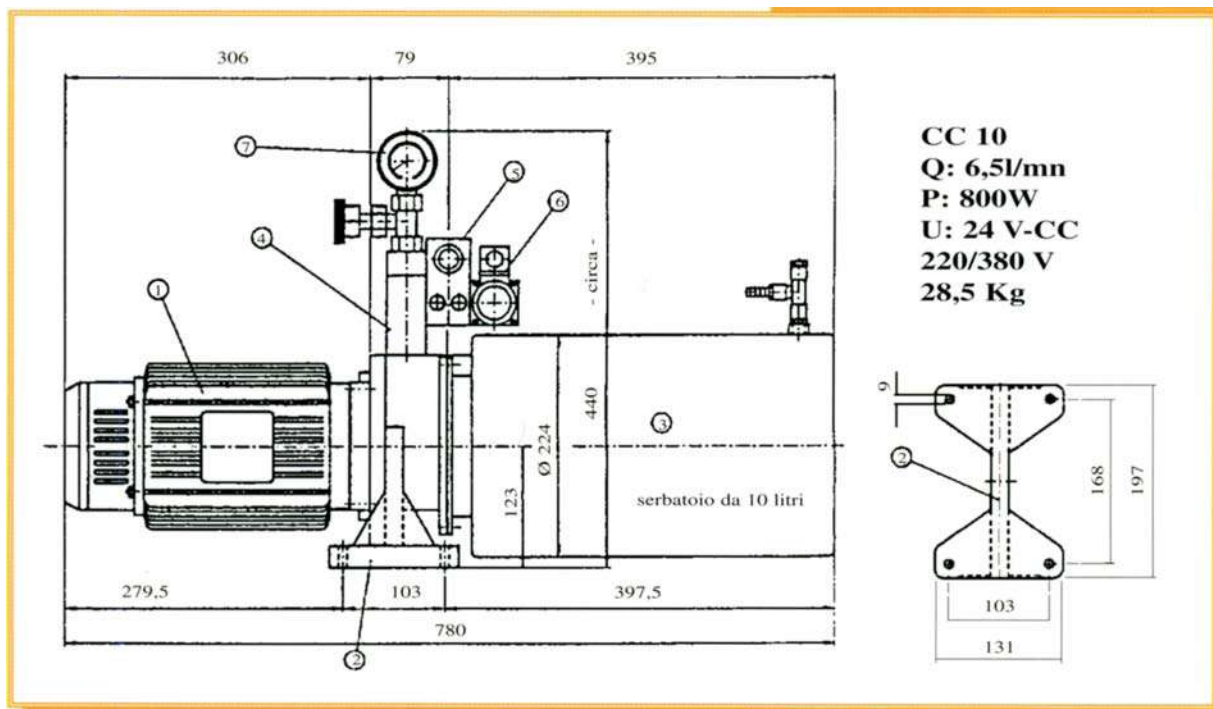

Timonería Electrohidráulica con by pass eléctrico *Electrohydraulic steering gear with electric by-pass*

Esta timonería es particularmente adaptada para embarcaciones de vela.

Es posible dirigir el timón mediante timonería mecánica cableada o con una central electrohidráulica comandada por un mando de autopilotaje.

El recambio de la timonería mecánica por la electrohidráulica es realizado mediante un comando eléctrico en el puente.

Centralina

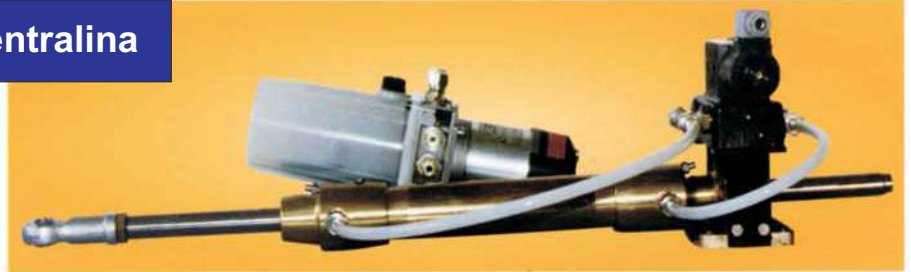

This steering gear is particularly suitable for sailing boats.

The rudder can be powered by a mechanical cable steering gear or an electrohydraulic power pack which would be commanded by joystick with autopilot

The change over from mechanical steering to electrohydraulic is done by an electrical command on the bridge

Para la timonería de servocontrol electrohidráulica disponemos del control remoto tipo TL.

We dispose of water-tight Remote Jog steering for our servo control electrohydraulic steering type TL.



También disponible en palanca

Also available as lever



Para la timonería de servocontrol electrohidráulica disponemos del control remoto tipo TL.

We dispose of water-tight Remote Jog steering for our servo control electrohydraulic steering type TLC.

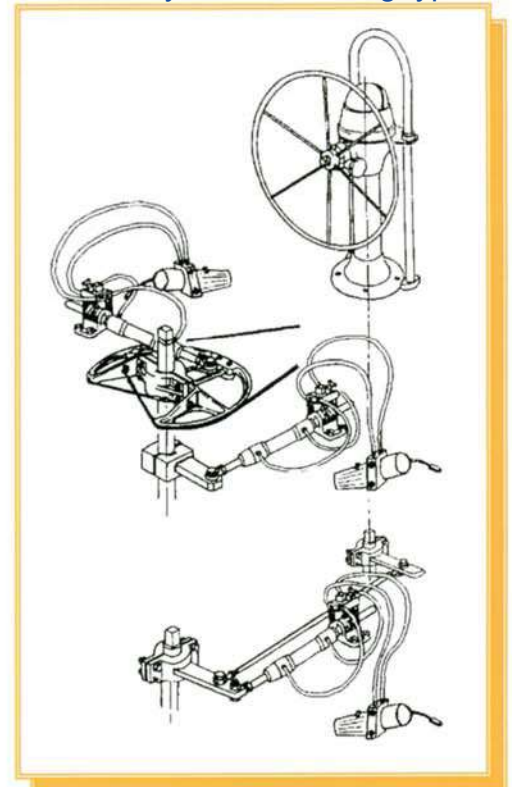

INDICADORES ELECTRÓNICOS DE ÁNGULO *ELECTRONICS RUDDER ANGLE INDICATORS*

TIPO - TYPE
RQ 52 (Ø 52) 12 - 24 V c.c.



TIPO - TYPE
TAB/U/M - IAB/03 (Ø 80) 12 - 24 V c.c.



Accesorios

Accessories



BRAZO TILLER
TILLER ARM



FLEXIBLE CON BY-PASS
FLEXIBLELS WITH BY - PASS



RACORERIA
CONNECTION FITTINGS



TUBO RILSAN
RILSAN PIPE



ACEITE
OIL

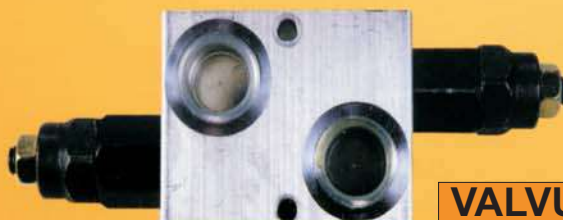

VALVULA DOBLE ANTIRRETORNO
DOUBLE ANTI-SHOCK VALVE

RUEDAS TIMÓN / STEERING WHEELS

TIPO/type 1
Ø cm:
30-37-42-49-52
60-65-70-80



TIPO/type 4 bis
Ø cm:
32-35-37-40

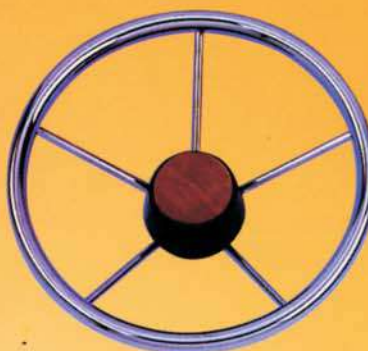

TIPO/type 2
Ø cm:
30-37-42-49-52
60-65-70-80-90
100-120-150



TIPO/type 4 C
Ø cm:
35-40
45



TIPO/type 3
Ø cm:
42-49-52-60
65-70-80



TIPO/type 5
Ø cm:
42-50-60-70
80-90-100-120



TIPO/type 4
Ø cm:
32-35-37
40-45



TIPO/type 11
Ø cm:
50-60-70-80



RUEDA TIMONES / STEERING WHEELS

TIPO/type 12
Ø cm:
35



TIPO/type 13
Ø cm:
100-120-130
150-160-180-200



TIPO/type 12 bis
Ø cm:
35



TIPO/type 6I
Ø cm:
40-45
50



TIPO/type 6
Ø cm:
40-45-50
60-70-80-90
100-120-130



TIPO/type 6B
Ø cm:
70-80-90
100-120-130



TIPO/type 9
Ø cm:
45-55-70
80



**Maniglia
pieghevole
Folding
handle**

CONTROL REMOTO HIDRÁULICO *Hydraulic remote - control*

TUBO / PIPE \varnothing 8x1

**RILSAN-RAME
RILSAN-COPPER**



CARACTERÍSTICAS:

El "telemando" de doble actuador hidráulico para embarcación universal se utiliza para desplazamientos de precisión controlados. Datos técnicos: Momento Máx.. 2 Kp x m; Ángulo máximo utilizable: 115 grados; Longitud máxima del tubo: 100m. Este telemando es recomendado para trabajar la dirección inversa a distancia.

Peso transmisor :kp=2; Peso deposito+ válvula: kp=4,2;

Peso actuador: kp=1,8

CHARACTERISTICS

Hydraulic double acting "Telecontrol" of universal board use for precision controlled displacing. Technical dat: max moment $M = 2 \text{ kpm}$, utilizable angle max 115° , pipes maximun longuer is $L = 100 \text{ m}$. This Telecontrol is recommended to work the direction inversor at distance.

Transmitter weight: kp = 2, Reservoir weight + valve: kp = 4,2, Actuator weight: kp = 1,8

Control remoto hidráulico 2 estaciones 1 motor
Hydraulic remote control 2 stations 1 motor

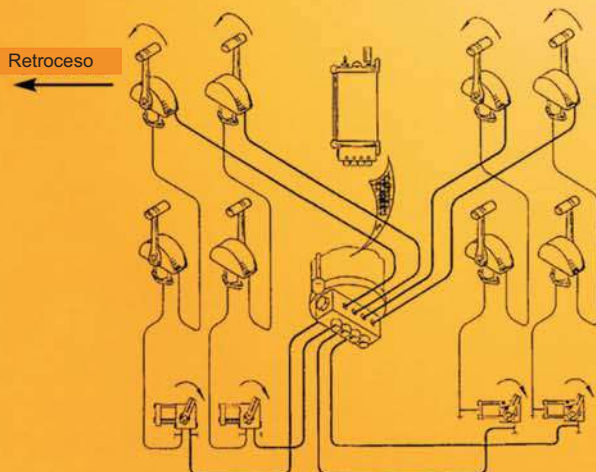
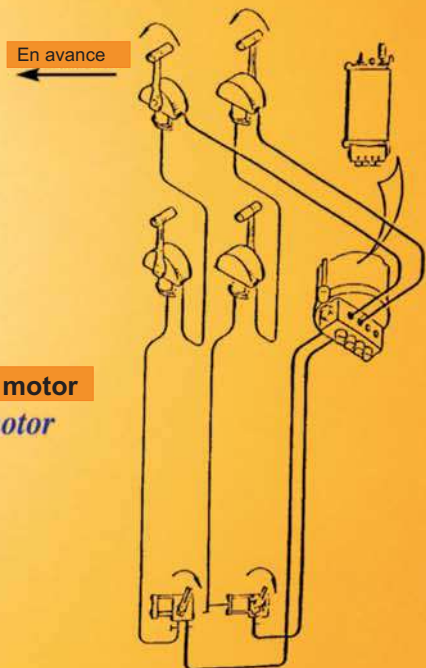

Control remoto hidráulico 2 estaciones 2 motores
Hydraulic remote control 2 stations 2 motors

SISTEMA ELECTRÓNICO DE COMANDO KE4

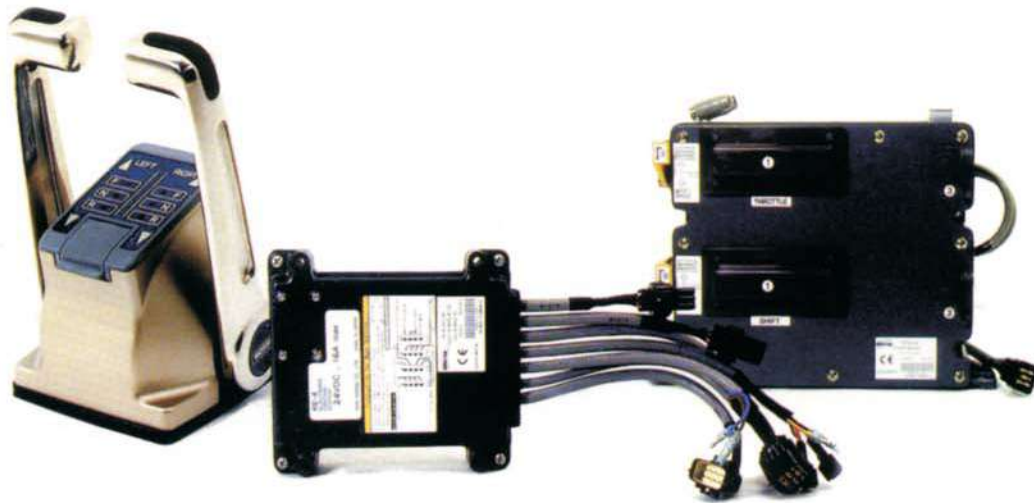

El sistema moderno

- ✎ Las mismas funciones que un control mecánico sin defectos.
- ✎ Mano de obra convencional
- ✎ Disponibilidad de expansión hasta 3 estaciones
- ✎ Sistemas de control simples. Posibilidad de utilizar únicamente el acelerador
- ✎ Función mecánica en caso de rotura
- ✎ Utilización del mismo cableado conector que en el motor
- ✎ Fácil instalación
- ✎ Colocación de interruptores en el control principal
- ✎ Disponible para sistemas de 12V o 24V
- ✎ Controles ergonómicos e impermeables
- ✎ Mismo programa diagnóstico
- ✎ Direcciones de retardo para inversión
- ✎ Opción disponible de sincronización del motor
- ✎ Certificados EMC/CE
- ✎ Disponibilidad de aceleración intermedia
- ✎ Protección de sobrecarga
- ✎ Control principal con interruptor de selección de estación
- ✎ Luces de emergencia (señal acústica opcional)
- ✎ Indicadores de marcha
- ✎ Interruptor de inicio
- ✎ Doble alimentación de potencia

Características principales

- ✎ Fuerza desarrollada: 27 kg en motor e inversor
- ✎ Carrera: 80mm acelerador
+- 40mm inversor
- ✎ Velocidad 50mm/seg
- ✎ Movimiento palanca: inversor 0-15 (grados)
acelerador 15-90 (grados)
- ✎ Voltaje: 12 y 24 Volt C.C
- ✎ Entorno:
 - . Impermeabilidad
 - . Temperatura funcionamiento: -25/+80 grados centígrados
 - . Posible funcionamiento: -40/120 grados centígrados
 - . Resistencia a la corrosión y rayos UV
 - . Útiles con emisores electromagnéticos standard